

30005 SERIES NEOPRENE PADS

An economical solution to general shock, vibration and noise problems in a variety of applications

Features

- Ideal for a wide range of industrial applications
- No tools, bolting or adhesives required for installation
- Neoprene isolator
- Pads can be easily cut to smaller sizes
- US Navy approved for Distributed Isolation Materials in construction of ships & submarines

Benefits

- Protects industrial equipment from damage caused by extended shock, noise and vibration exposure
- Easily installed or relocated
- Can be used in a broad range of applications where moderate shock, vibration and noise reduction is required
- Low maintenance
- Resistant to oils, most solvents and ozone

Load Range

- Provides drift resistance up to 50 psi

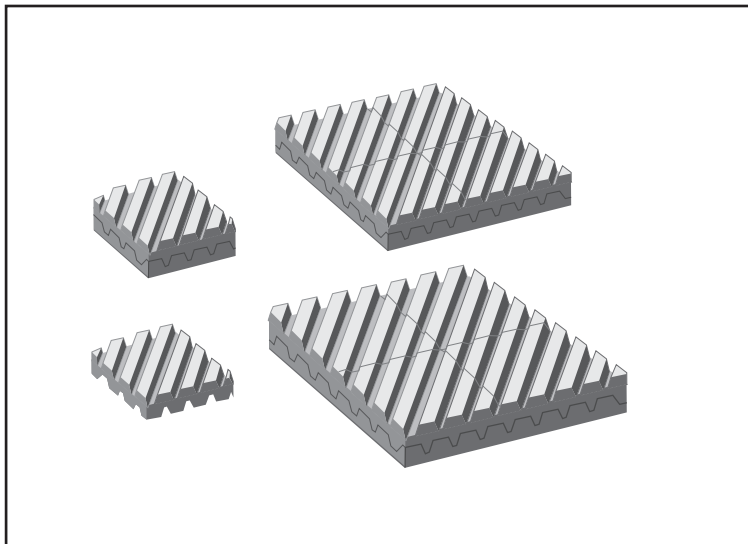

Barry Neoprene Pads are designed for use as a general purpose shock, vibration and noise attenuator or where the advantages of elastomeric characteristics are required but a specific type of isolator has not been called out.

Applications

- Drill Presses
- Microscopes
- Printing Equipment
- Riveters
- Sanders and Saws
- Work Benches

NATURAL FREQUENCY	20 - 35 Hertz
TRANSMISSIBILITY AT RESONANCE	8:1
RESILIENT ELEMENT	Neoprene
STANDARD MATERIALS	Neoprene
WEIGHT	4" x 4" square = 2 oz.

Environmental Data

- Neoprene elastomer has an operating temperature range of -20°F to +180°F (-30°C to +85°C) and is resistant to oils, most solvents, salt spray and ozone.

Neoprene Pad Series

Dimensions & Performance Characteristics

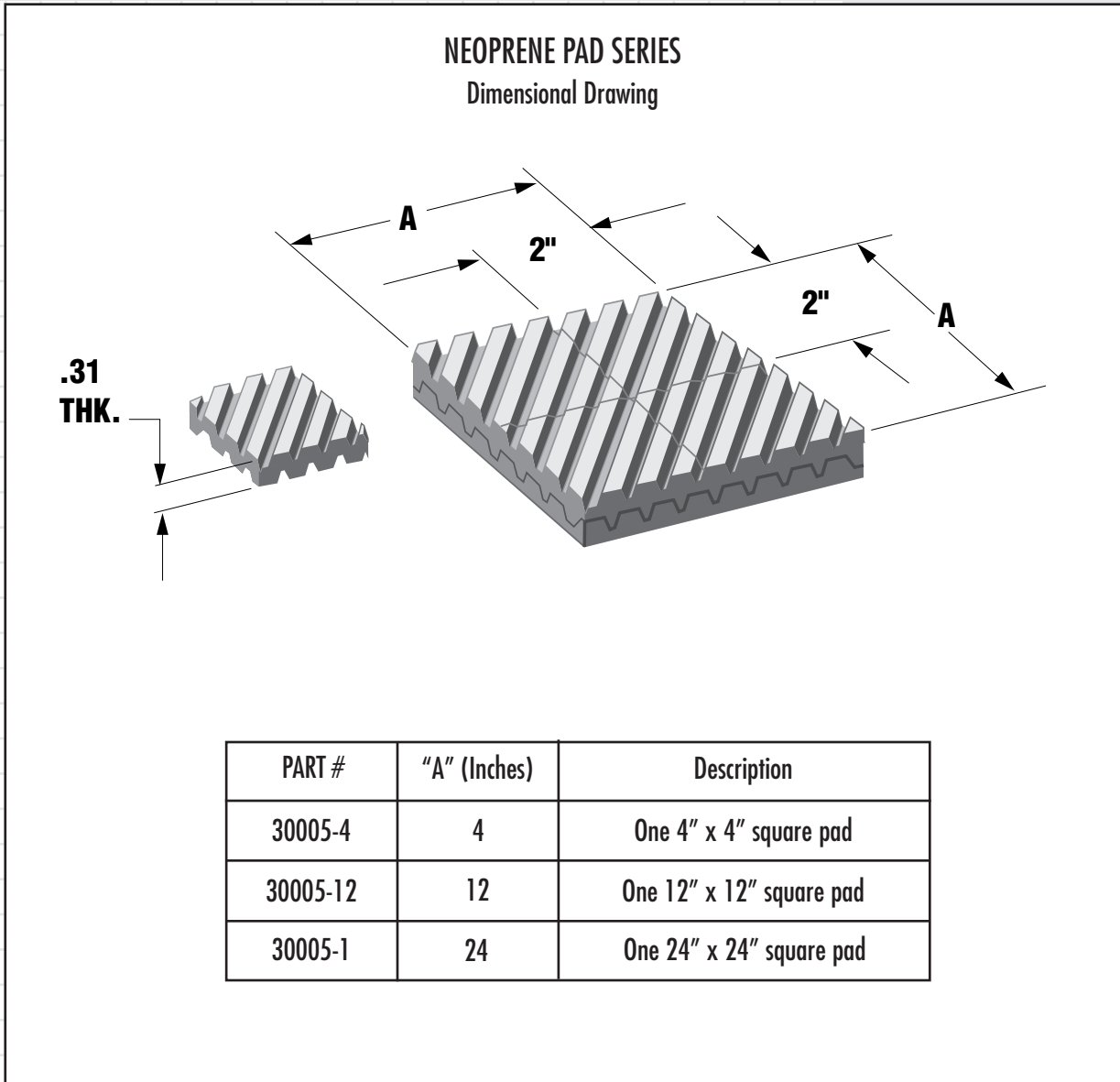

Barry Controls
40 Guest Street • Brighton, MA 02135-9105 • (617) 787-1555 • Fax (617) 787-7807

Dimensions and data are subject to change without notice.

For technical, design, or application assistance, call toll free:

1-800-BARRY MA